

Scambiatori Aria-olio Serie 2000KBV

*Air-oil heat-exchangers
2000KBV Series*

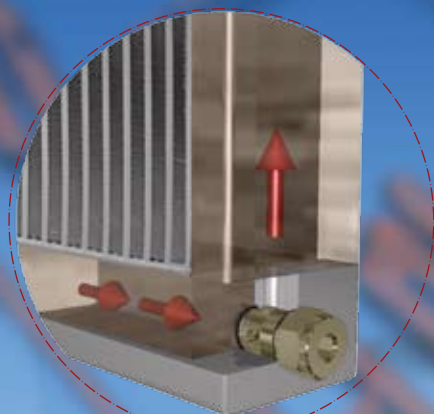

ENNEMECI

Gli scambiatori di calore aria-olio EMMEGI, sono impiegati per il raffreddamento di circuiti oleodinamici usando, come fluido raffreddante, l'aria ambiente convogliata sulla radiante da una ventola azionata da un motore elettrico o idraulico. La massa radiante, in lega d'alluminio ad alta resistenza, è ottenuta mediante un processo costruttivo di saldobrasatura sottovuoto. La particolare configurazione dei condotti aumenta la turbolenza del fluido e di conseguenza la capacità di scambio; inoltre la presenza di speciali turbolatori sull'alettatura del pacco radiante, migliora ulteriormente il coefficiente di trasmissione totale. Il risultato è un prodotto tecnologicamente avanzato di dimensioni contenute, leggero e robusto. Gli scambiatori aria-olio serie KBV- nascono dalle esigenze applicative ad ampio raggio espresse dal mercato. Punto di forza di questi prodotti è rappresentato dal by-pass integrato che ne amplifica la semplicità d'uso, eliminando la necessità di dovere aggiungere da parte del cliente una valvola autonoma, assicurando così elevata funzionalità.

Fluidi compatibili

- . OIL MINERALI, HL, HLP.
- . EMULSIONI ACQUA-OLIO
- . ACQUA-GLICOLE
- . Per altri fluidi consultare EMMEGI.

Specifiche tecniche Masse Radianti

- . Materiale: alluminio "long life".
- . Pressione d'esercizio: 20 bar.
- . Pressione di collaudo: 35 bar.
- . Temperatura max d'esercizio: 120°C
- . Per particolari atmosfere aggressive consultare l'EMMEGI.

Installazione

Lo scambiatore può essere montato in posizione orizzontale o verticale, rispettando la distanza minima dalla parete (vedi fig. 1), in modo da assicurare un naturale afflusso e deflusso dell'aria di raffreddamento.

Lo scambiatore è installato di norma, sulle tubazioni di ritorno dell'olio del serbatoio; deve inoltre essere protetto da urti e vibrazioni meccaniche mediante supporti e collegato all'impianto con tubazioni flessibili. È necessario evitare che sia sottoposto a brusche variazioni di portata, colpi d'ariete e pulsazioni continue che danneggiano in modo irreversibile la radiante.

EMMEGI air-oil heat exchangers are used for cooling oil hydraulic systems using as the coolant ambient air that passes over the radiant by means of a fan operated by an electric or hydraulic motor. The cooler element, in high resistance aluminium alloy, is obtained by means of a braze-welding process carried out under vacuum. The particular configuration of the cooling pipes increase the turbulence of the fluid consequently of the exchange capacity; moreover, the presence of special jets on the cooler finning further improves the total transmission coefficient. The result is a very small, light and robust technologically advanced product. The air-oil heat-exchangers KBV Series were born to answer the large application needs of the market. The main characteristic of this new products is the integrated by-pass valve that will simplify their employ and will avoid the customers to add an external and independent valve. This will guarantee a very high efficiency.

Compatible fluids

- . MINERAL OILS; HL; HLP.
- . WATER-OIL EMULSION.
- . WATER-GLYCOL.
- . Consults EMMEGI for other fluids.

Technical specification of Cooler Element

- . Material: "long life" aluminium.
- . Operating pressure: 20 bar
- . Test pressure: 35 bar.
- . Max operating temperature: 120°C.
- . For specially "aggressive" atmospheres contact EMMEGI.

Installation

The exchangers can be fitted in a horizontal position, respecting the minimum distance from the wall (see fig.1) so as to ensure a natural flow of cooling air. The exchangers is usually installed on oil tank return piping; it must also be protected from impacts and mechanical vibrations by supports and must be connected to the plant with flexible pipes. Avoid subjecting the exchanger to sudden changes in flow, hammering and pulsations that can cause irreversible damage to the element.

Manutenzione

È buona norma prestare particolare attenzione alla pulizia della massa radiante per garantire un naturale ricambio d'aria, ed evitare una diminuzione dell'efficienza termica.

Pulizia lato olio

Per eseguire la pulizia lato olio, lo scambiatore dovrà essere smontato. Lo sporco può essere rimosso flussando in controcorrente un prodotto sgrassante, compatibile con alluminio. Effettuate un lavaggio con olio idraulico prima di ricollegare il prodotto all'impianto.

Pulizia lato aria

La pulizia lato aria può essere effettuata con aria compressa o acqua, con direzione del getto parallelo alle alette per non danneggiare. Lo sporco oleoso o grasso può essere rimosso con getto di vapore o acqua calda. Durante questa operazione, il motore elettrico non deve essere collegato alla tensione, e dovrà essere adeguatamente protetto.

Esempio di scelta dello scambiatore

Per effettuare la scelta dello scambiatore si procede come segue:

Potenza da dissipare : 8,7 [KW]
Portata olio ISO VG 32 : 90 [lpm]
Temperatura ingresso olio : 60 [°C]
Temperatura ambiente : 30 [°C]
Ventola azionata da motore elettrico 230/400V-50Hz.

Si calcola la potenza specificata di scambio espressa in KW/°C, conoscendo la potenza da dissipare e il ΔT (differenza tra la temperatura olio ingresso e la temperatura ambiente).

$$P = \frac{8.7 \text{ KW}}{60^\circ - 30^\circ} = 0.29 \text{ KW/}^\circ\text{C}$$

Nota la portata olio (90 lpm) e la potenza specifica di scambio (0.29 KW/°C) si procede alla ricerca del prodotto avvalendosi dei grafici riportati a catalogo, relativi ai singoli modelli.

Maintenance

You should be particularly carefully in cleaning the cooler element to guarantee a natural exchange of air, in order to prevent a reduction in thermal efficiency

Cleaning oil side

The exchanger should be dismantled to clean on the oil side. The dirt can be removed by flushing, in counter-current, de-greasing substance, compatible with aluminium. Wash with hydraulic oil before re-connecting the product to the plant.

Cleaning air side

Cleaning on the air side can be done using compressed air or water, directing the jet parallel to the fins so as not to damage them. Oily dirt or grease can be removed with a jet of steam or hot water. During this operation, the electric motor must be disconnected from the voltage supply, and must be adequately protected.

Example of how to choose a heat exchanger

Proceed with sizing the exchanger, with a knowledge of the data as the example below shows:

Power to dissipate : 8,7 [KW]
ISO VG 32 oil flow : 90 [lpm]
Oil input temperature : 60 [°C]
Ambient temperature : 30 [°C]
Fan operating with an electric motor 230/400V-50Hz.

You can then calculate the specific heat exchange power KW/°C if you know the power to dissipate and the ΔT (the difference between the oil input temperature and the ambient temperature).

$$P = \frac{8.7 \text{ KW}}{60^\circ - 30^\circ} = 0.29 \text{ KW/}^\circ\text{C}$$

Note the oil flow (90 lpm) and specific exchange power (0.29 KW/°C), product research is made by referring to the graph in the catalogue which is relevant to each model.

Dati tecnici Technical Data



P/N	V	Hz	kW	A	rpm	ø Fan	dB(A)	(m³/h)	IP	lt	Kg
2W3001 ###	230 AC	50	0,189	0,85	2520	300	78	2220	44	1,6	15
2W3003 ###	230-400 AC	50/60	0,195	0,43	2600	300	76	2500	44		15
2W3004 ###	230-400 AC B14	50/60	0,370	1,03	1370	300	70	1850	55		20
2W3012 ###	12 DC	/	0,180	12,5	3000	305	80	1920	68		14
2W3024 ###	24 DC	/	0,180	6	3000	305	83	2100	68		14
2W3056 ###	Prepared for Gr.2 hydraulic monitor					300			/		15

Contattare EMMEGI Contact EMMEGI

Diagramma rendimento Performance diagram

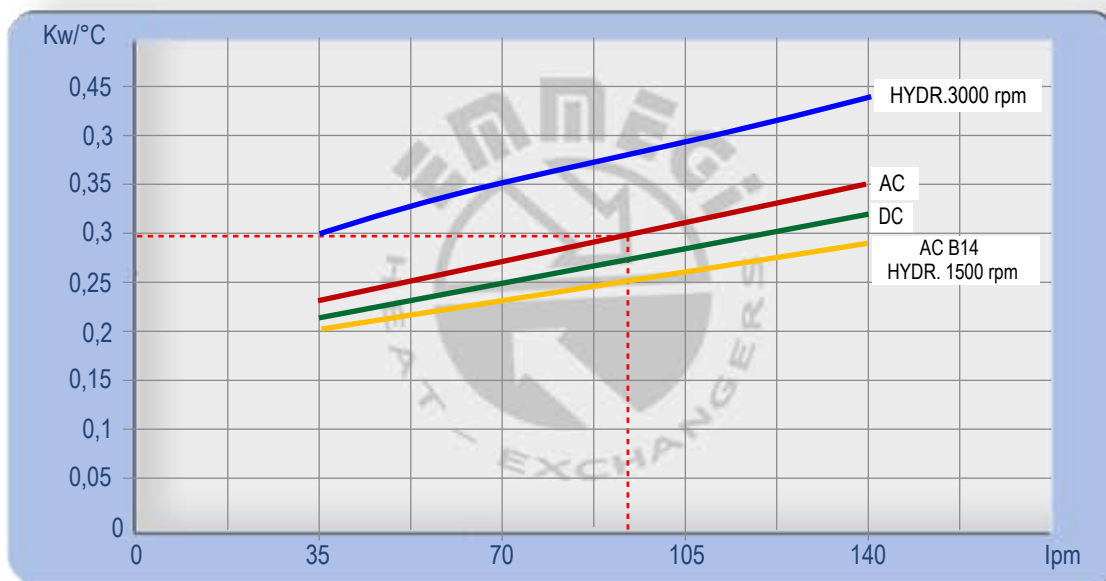

Lo scambiatore selezionato risulta il modello:
MG AIR 2030KBV - 230/400 - 50Hz
cod. 2W3003###.

The exchanger selected is the following model:
MG AIR 2030KBV - 230/400V - 50Hz
cod. 2W3003###.

Per la completa identificazione dello scambiatore consultare la pagina "DENOMINAZIONE CODICE PRODOTTO". Nel caso non siano conosciuti tutti i dati, per la scelta prendere contatto **EMMEGI**.

For a complete description of the exchanger consult the "PRODUCT ORDERING CODE" page. If you do not know all the data required for selecting the model, contact **EMMEGI**.

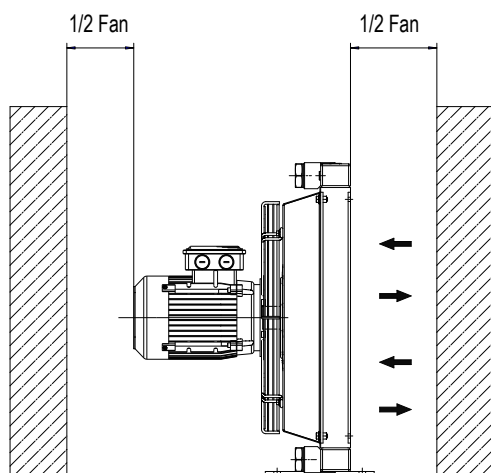
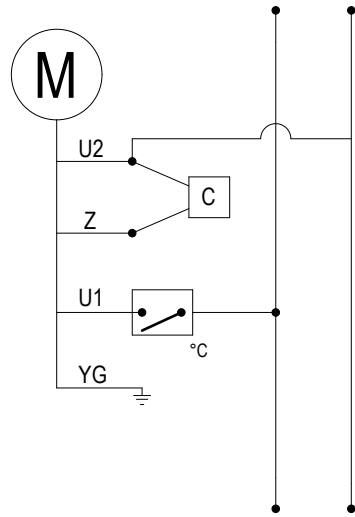

Fig.1

Collegamenti elettrici

Electric Wiring



230V AC 1 PHASE

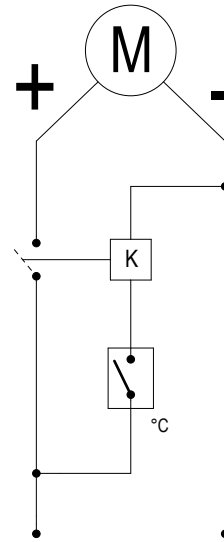

12-24V DC

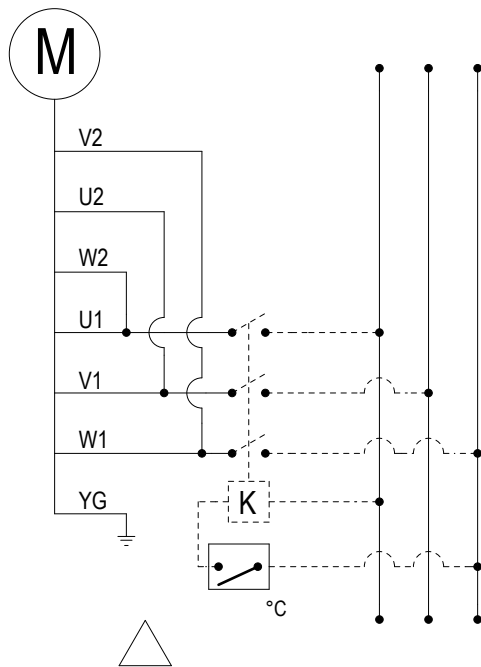

230V AC 3 PHASE

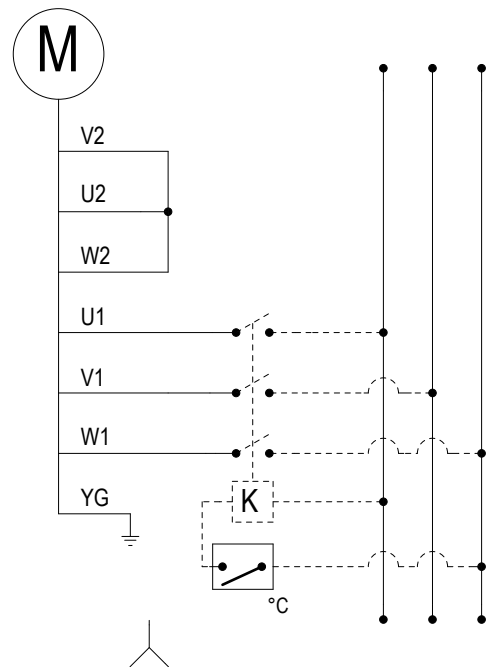

400V AC 3 PHASE

°C = Termostato NA./Thermostat No.
K = Relè/Relay

CLIENTE <i>COMPANY</i>	
RICHIEDENTE <i>NAME</i>	

ARIA-OLIO *AIR-OIL*

PORTATA OLIO <i>OIL FLOW RATE</i>	Imp	
POTENZA INSTALLATA <i>TOTAL POWER</i>	KW	
POTENZA DA DISSIPARE <i>POWER TO BE DISSIPATED</i>	KW	
TEMPERATURA INGRESSO OLIO <i>OIL TEMPERATURE INLET</i>	°C	
TEMPERATURA ARIA MAX <i>MAX AMBIENT TEMPERATURE</i>	°C	
VISCOSITÀ OLIO <i>OIL VISCOSITY</i>	cst	
PRESSIONE DI LAVORO <i>WORKING PRESSURE</i>	bar	

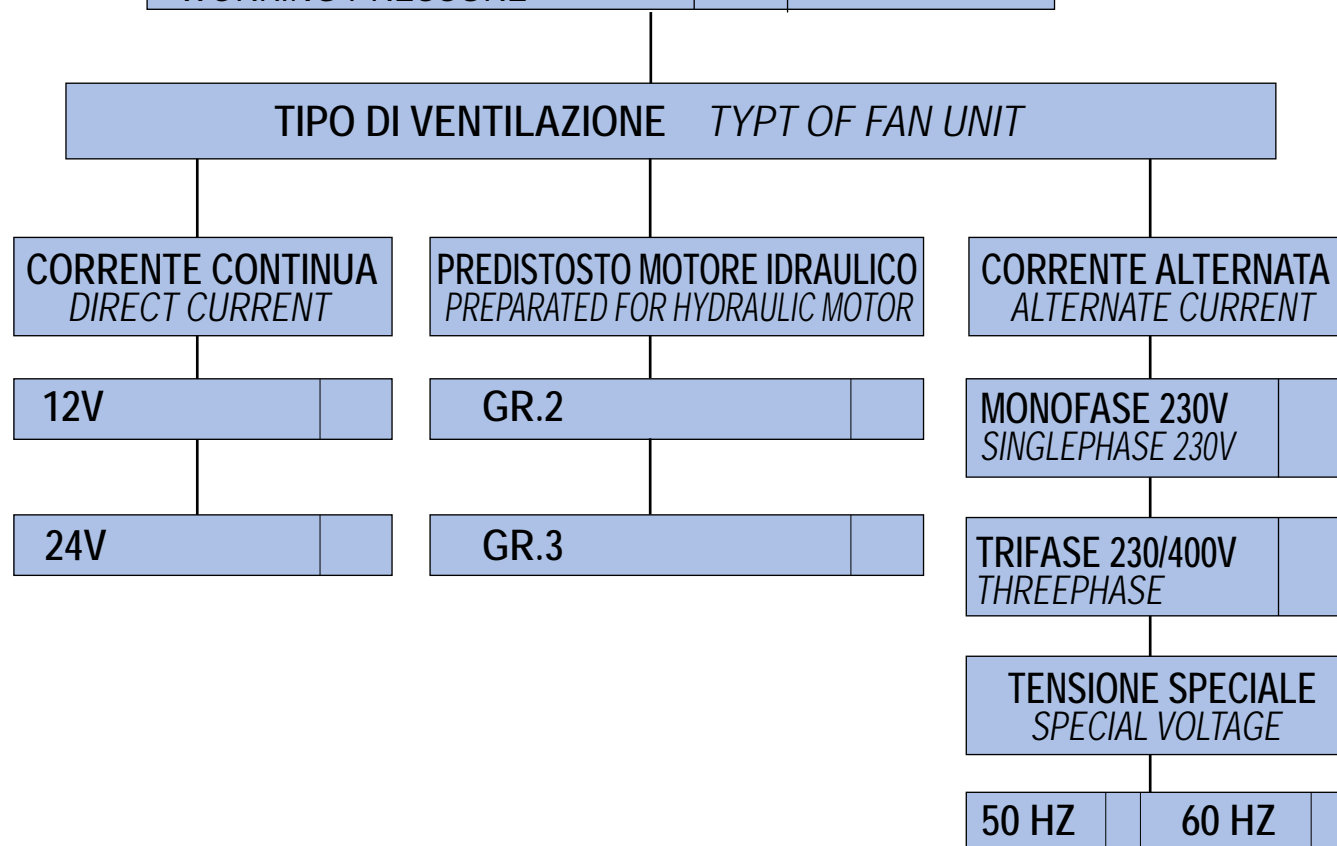

2

W24

03

2

01

TIPO DI SISTEMA COOLER SERIES

W24 (MG AIR 2024KBV)

TIPO DI MOTORIZZAZIONE FAN MOTOR TYPE

- 01 AC 230V 50 Hz
- 03 AC 230V-400V 50Hz
- 04 AC 230V-400V 50-60 Hz (B14)
- 12 DC 12V
- 24 DC 24V
- 56 Pred. per mot. idr. gr. 2 Prep. for hydr. mot. gr. 2

TERMOSTATI THERMOSTATS

- | | | | |
|---|---------------------------------|---------------------------------|--------------|
| 1 | Termostato fisso | Fixed thermostat | 40-28° |
| 2 | Termostato fisso | Fixed thermostat | 50-38° |
| 3 | Termostato fisso | Fixed thermostat | 60-48° |
| 4 | Termostato fisso | Fixed thermostat | 70-58° |
| 5 | Termostato fisso | Fixed thermostat | 80-68° |
| 6 | Termostato fisso | Fixed thermostat | 90-78° |
| 8 | Termostato regolabile | Adjustable thermostat | 0-90° (TC2) |
| 9 | Termostato regolabile collegato | Connected adjustable thermostat | 0-120° (TC2) |

TIPO DI VENTILAZIONE VENTILATING TYPE

- 01 Aspirante Suction air flow
- 02 Soffiante Blowing air flow

Dati tecnici valvola by-pass Technical data by-pass valve - (1.5 bar)

Valvola cartuccia tipo 2 / Cartridge valve type 2 - (1.5 bar)

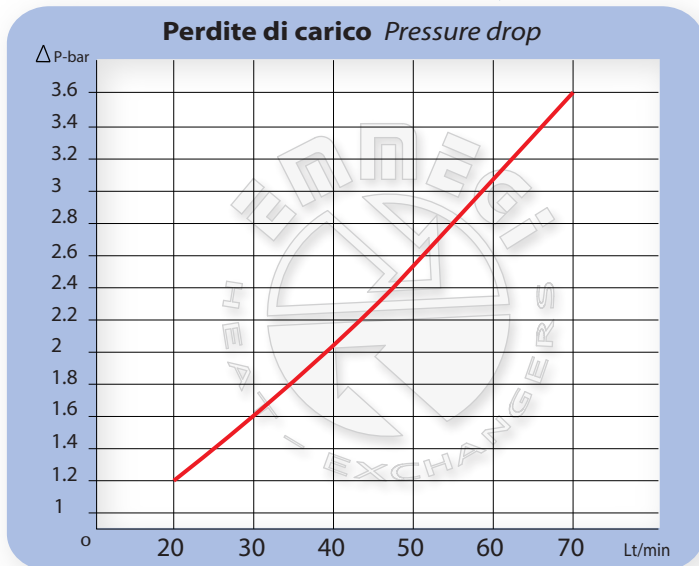

Schema idraulico Hydraulic circuit

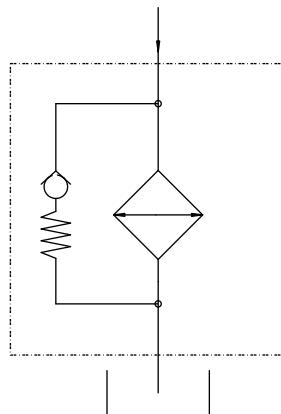

Gli scambiatori aria-olio serie KBV- nascono dalle esigenze applicative ad ampio raggio espresse dal mercato. Punto di forza di questi prodotti é rappresentato dal by-pass integrato che ne amplifica la semplicità d' uso, eliminando la necessità di dovere aggiungere da parte del cliente una valvola autonoma, assicurando così elevata funzionalità.

The air-oil heat-exchangers KBV Series were born to answer the large application needs of the market.

The main characteristic of this new products is the integrated by-pass valve that will simplify their employ and will avoid the customers to add an external and independent valve.

This will guarantee a very high efficiency.

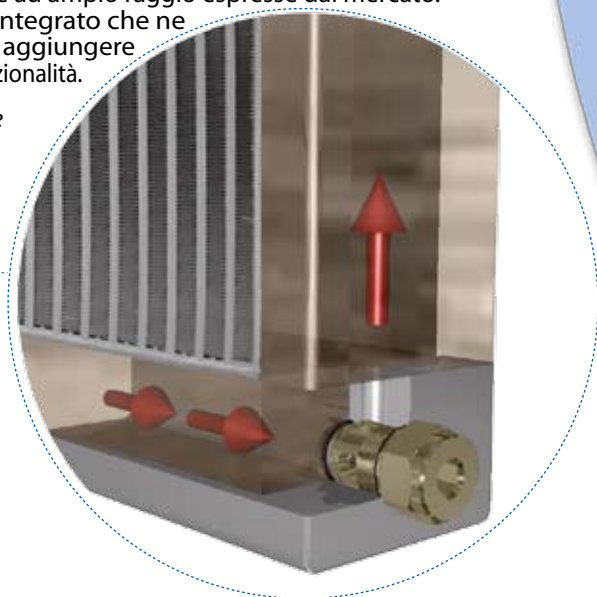

Detail



Dimensioni Dimensions

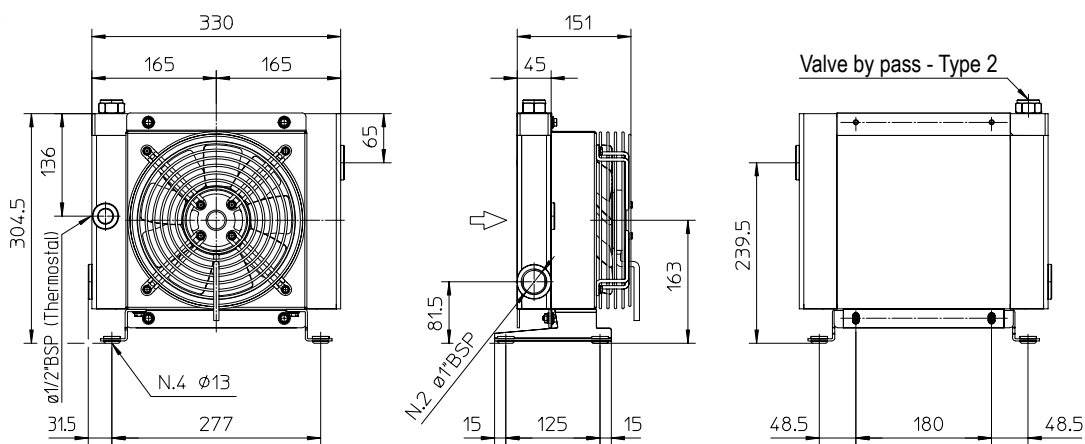

P/N 2W1501###
P/N 2W1503###

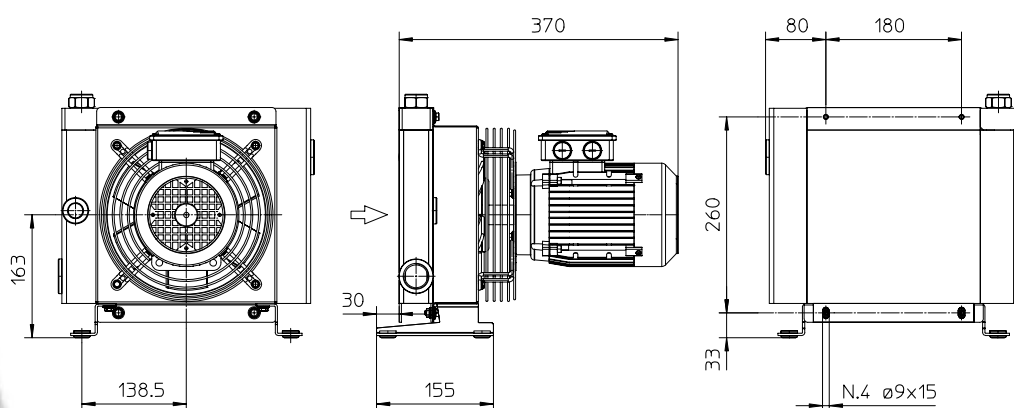

P/N 2W1504###

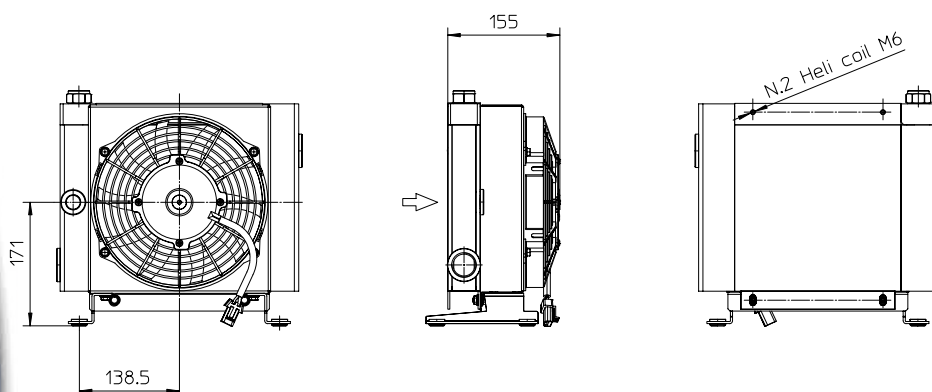

P/N 2W1512###
P/N 2W1524###

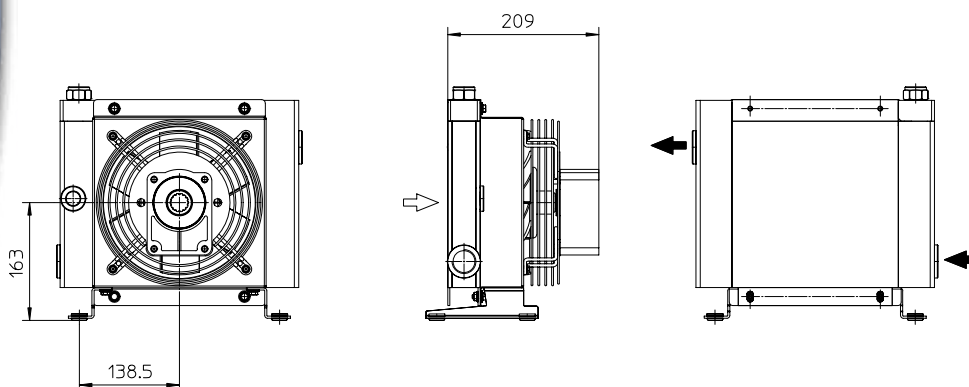

P/N 2W1556###

Le dimensioni di ingombro e le caratteristiche tecniche non sono impegnative
Over-all dimensions and technical characteristic are not binding

MG2015KBV

Dati tecnici Technical Data



P/N	V	Hz	kW	A	rpm	ø Fan	dB(A)	(m³/h)	IP	lt	Kg
2W1501###	230 AC	50	0,067	0,29	2770	200	68	700	44	0,5	7
2W1503###	230-400 AC	50/60	0,068	0,15	2600	200	69	720	44		7
2W1504###	230-400 B14 AC	50/60	0,250	0,72	1350	200	61	415	55		10
2W1512###	12 DC	/	0,09	6,1	3100	225	72	880	68		6,5
2W1524###	24 DC	/	0,10	2,9	3000	225	73	865	68		6,5
2W1556###	Prepared for Gr.2 hydraulic monitor					200			/		6

Contattare EMMEGI Contact EMMEGI

Diagramma rendimento Performance diagram

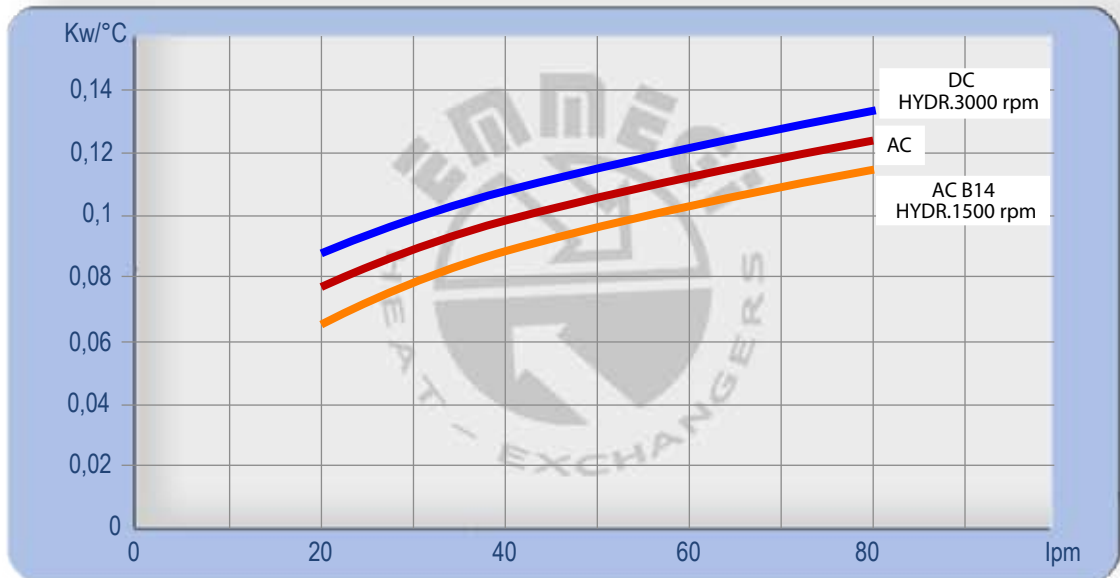

Perdite di carico Pressure drop (ISO VG 32)

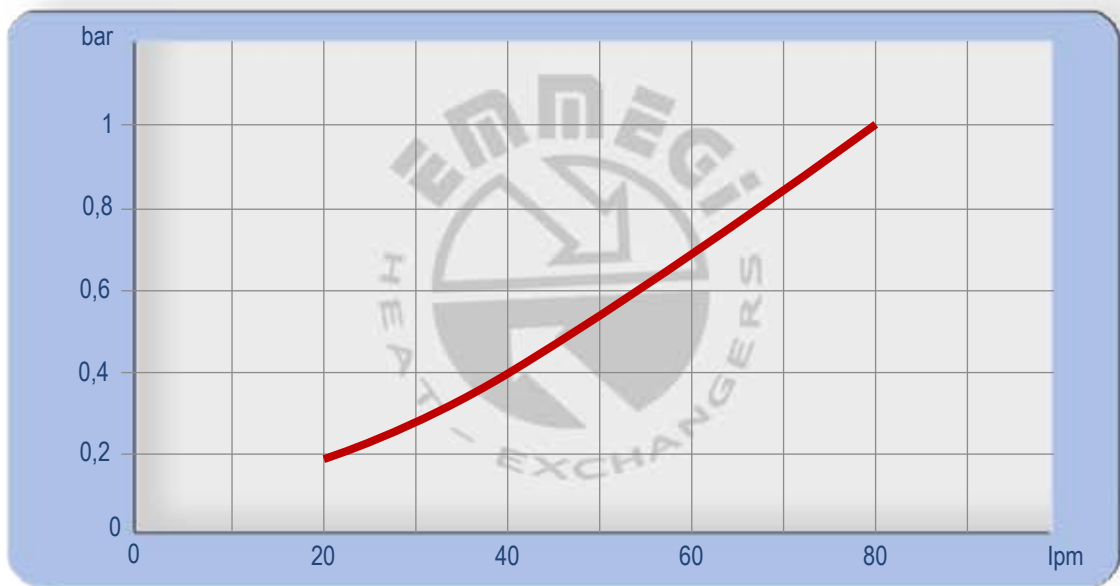

Fattore di correzione - F -(perdite di carico) Correction factor - F - (Pressure drop)

cst	10	15	20	30	40	50	60	80	100	200	300
F	0,5	0,65	0,77	1	1,2	1,4	1,6	1,9	2,1	3,3	4,3

MG2015K1BV

Dimensioni Dimensions

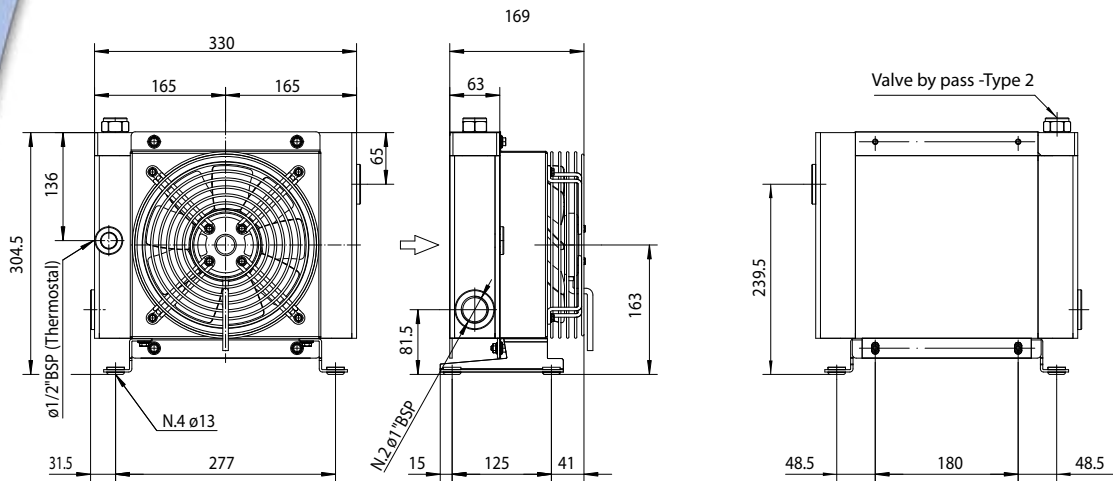

P/N 2W2001###
P/N 2W2003###

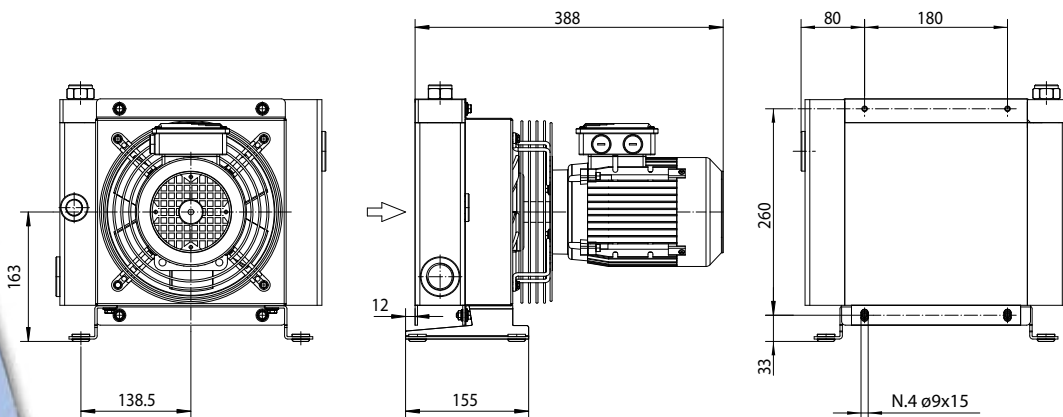

P/N 2W2004###

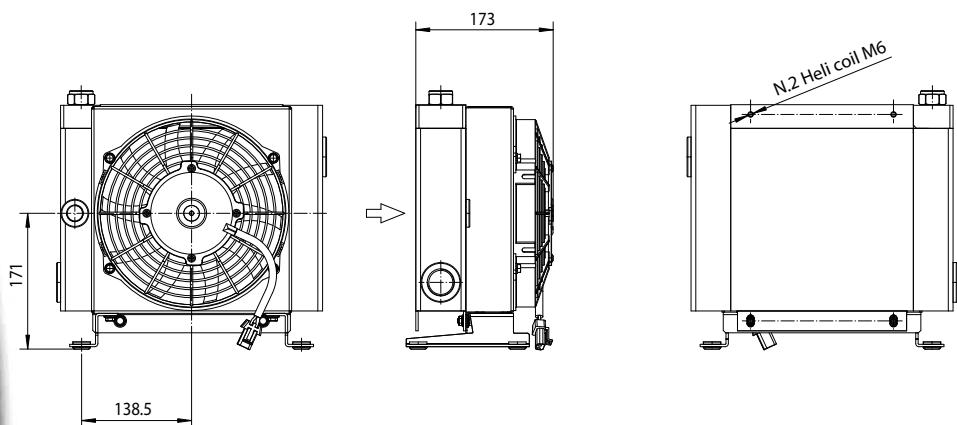

P/N 2W2012###
P/N 2W2024###

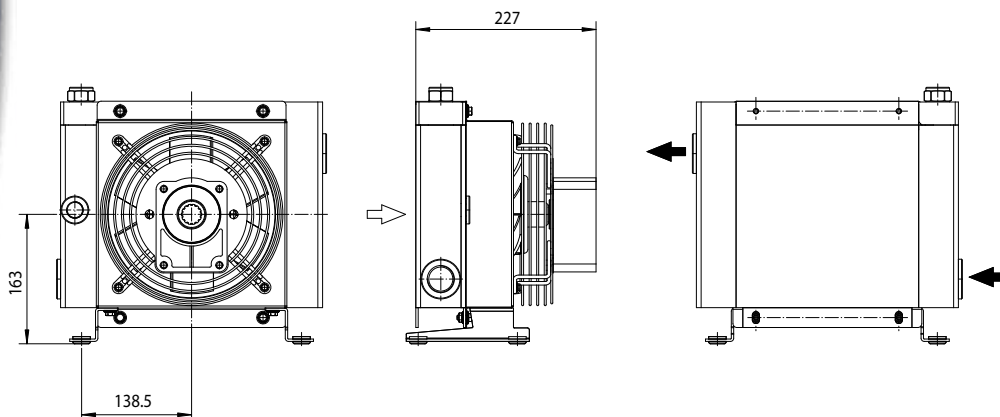

P/N 2W2056###

Le dimensioni di ingombro e le caratteristiche tecniche non sono impegnative
Over-all dimensions and technical characteristic are not binding

MG2020KBV

Dati tecnici Technical Data



P/N	V	Hz	kW	A	rpm	ø Fan	dB(A)	(m³/h)	IP	lt	Kg
2W2001###	230 AC	50	0,067	0,29	2770	200	68	675	44	0,7	8
2W2003###	230-400 AC	50/60	0,068	0,15	2600	200	68	645	44		8
2W2004###	230-400 B14 AC	50/60	0,250	0,7	1350	200	64	390	55		11
2W2012###	12 DC	/	0,09	5,9	3100	225	72	795	68		7
2W2024###	24 DC	/	0,10	3,1	3000	225	72	785	68		7
2W2056###	Prepared for Gr.2 hydraulic monitor					200			/		7

Contattare EMMEGI Contact EMMEGI

Diagramma rendimento Performance diagram

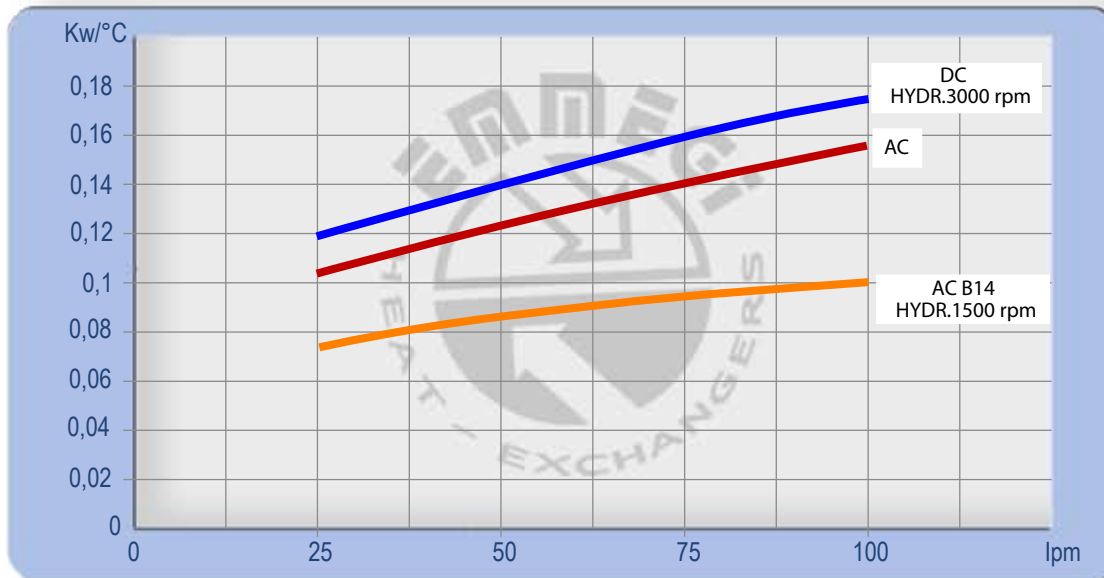

Perdite di carico Pressure drop (ISO VG 32)

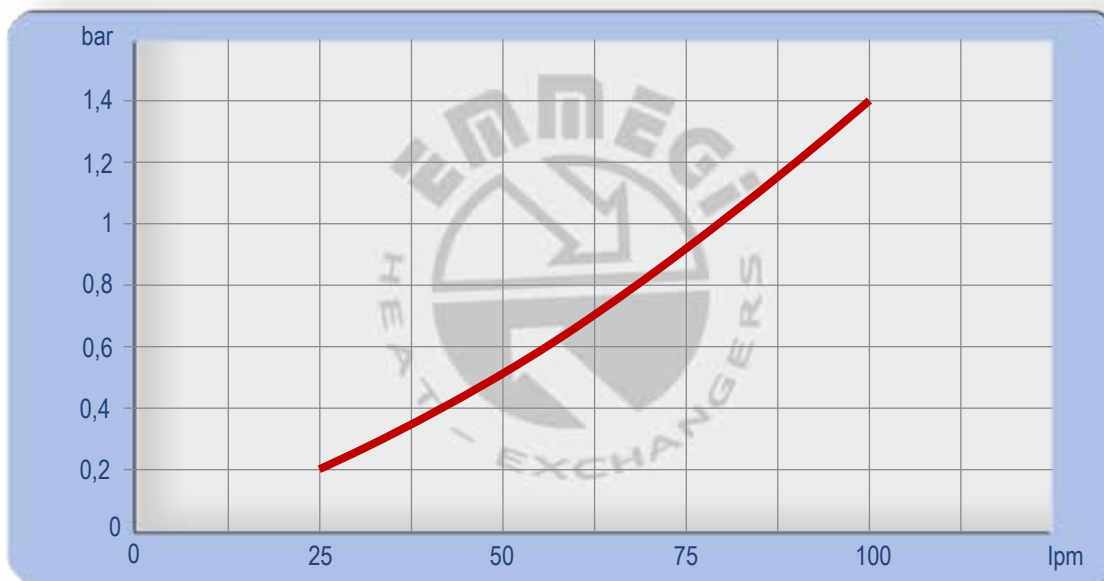

Fattore di correzione - F -(perdite di carico) Correction factor - F - (Pressure drop)

cst	10	15	20	30	40	50	60	80	100	200	300
F	0,5	0,65	0,77	1	1,2	1,4	1,6	1,9	2,1	3,3	4,3

MG2020KBV

Dimensioni Dimensions

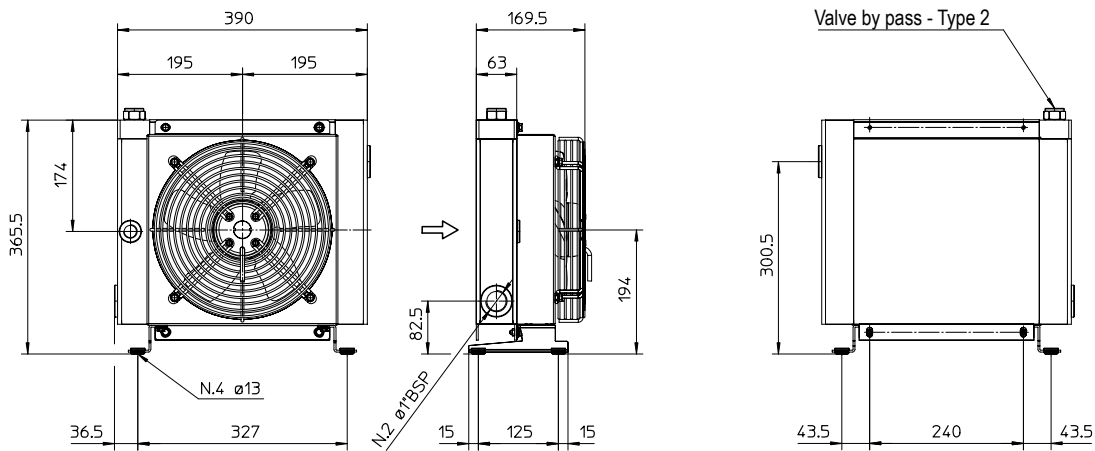

P/N 2W2401###
P/N 2W2403###

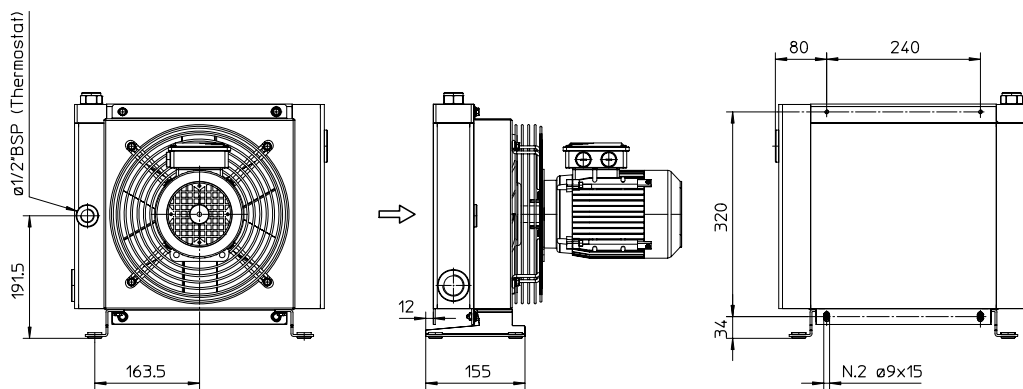

P/N 2W2404###

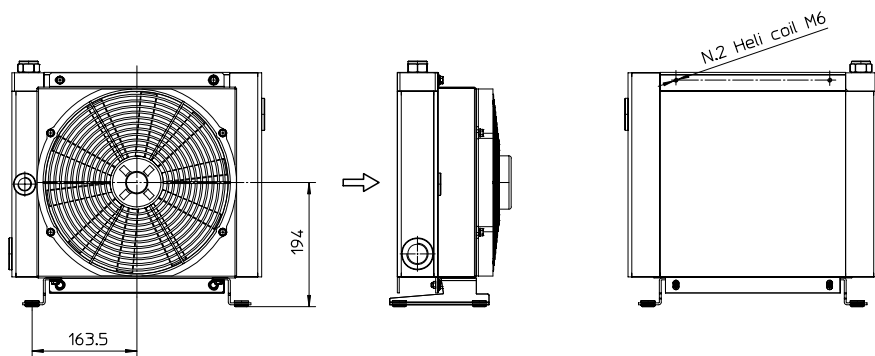

P/N 2W2412###
P/N 2W2424###

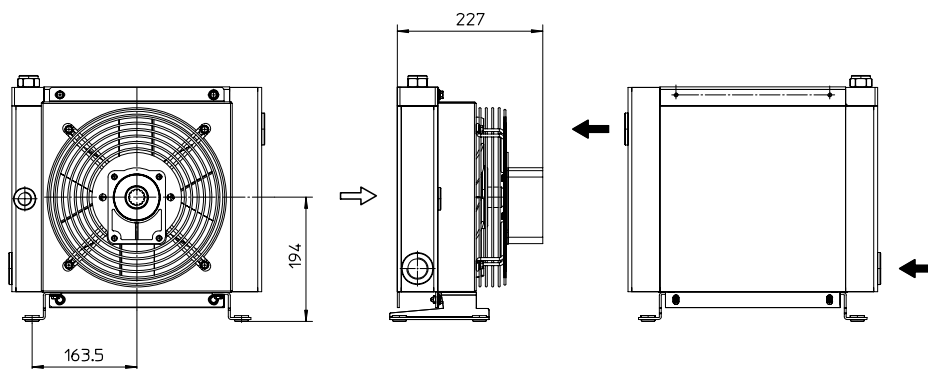

P/N 2W2456###

Le dimensioni di ingombro e le caratteristiche tecniche non sono impegnative
Over-all dimensions and technical characteristic are not binding

MG2024KBV

Dati tecnici Technical Data



P/N	V	Hz	kW	A	rpm	ø Fan	dB(A)	(m³/h)	IP	lt	Kg
2W2401###	230 AC	50	0,108	0,48	2525	250	72	1350	44	1	11
2W2403###	230-400 AC	50/60	0,105	0,22	2500	250	72	1300	44		11
2W2404###	230-400 B14 AC	50/60	0,250	0,71	1450	250	64	1000	55		16
2W2412###	12 DC	/	0,110	7,1	3000	280	72	1180	68		10
2W2424###	24 DC	/	0,110	3,8	3000	280	74	1280	68		10
2W2456###	Prepared for Gr.2 hydraulic monitor					250			/		10

Contattare EMMEGI Contact EMMEGI

Diagramma rendimento Performance diagram

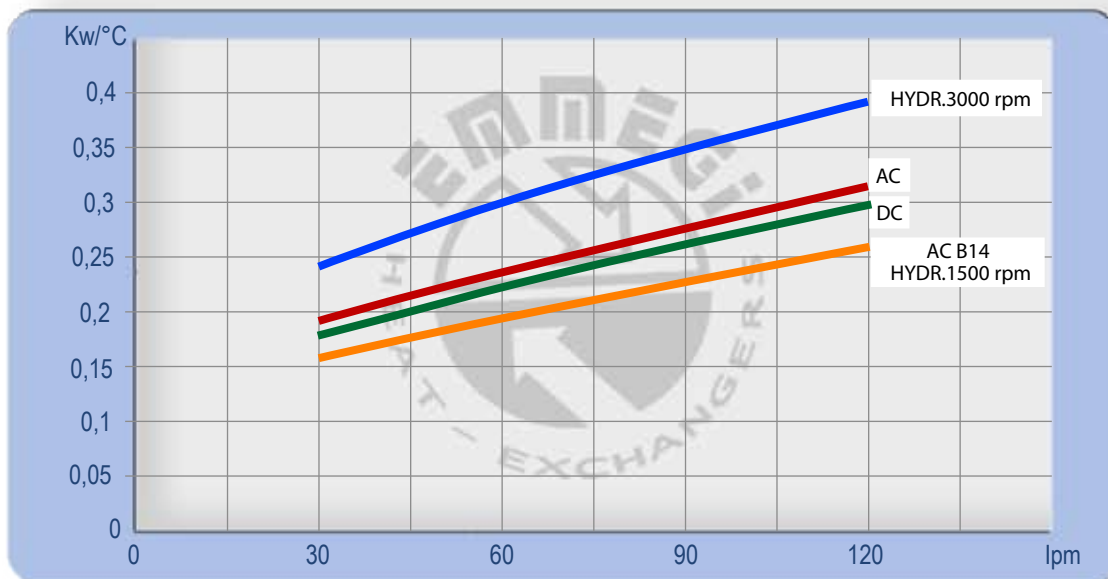

Perdite di carico Pressure drop (ISO VG 32)

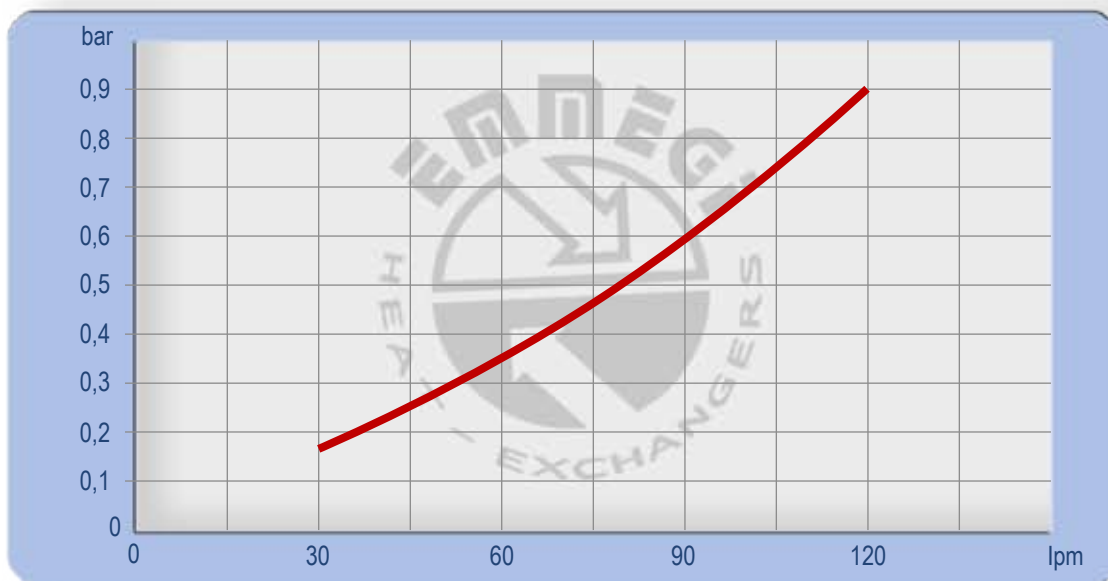

Fattore di correzione - F -(perdite di carico) Correction factor - F - (Pressure drop)

cst	10	15	20	30	40	50	60	80	100	200	300
F	0,5	0,65	0,77	1	1,2	1,4	1,6	1,9	2,1	3,3	4,3

Dimensioni Dimensions

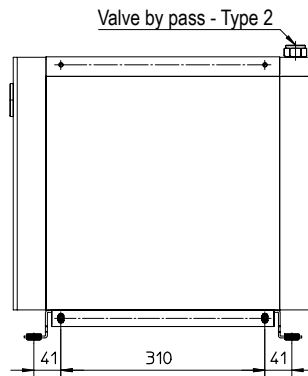
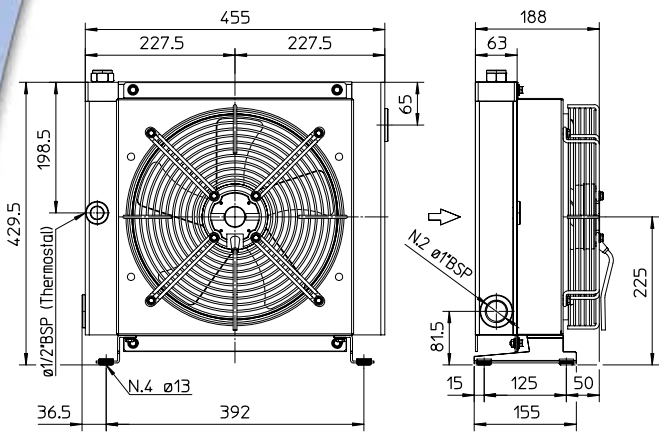

P/N 2W3001###
P/N 2W3003###

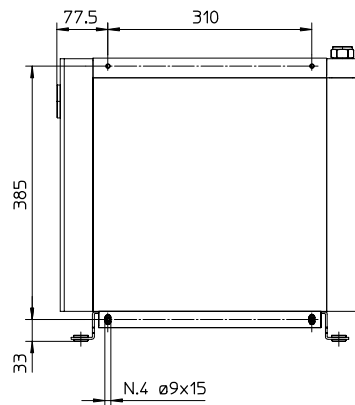
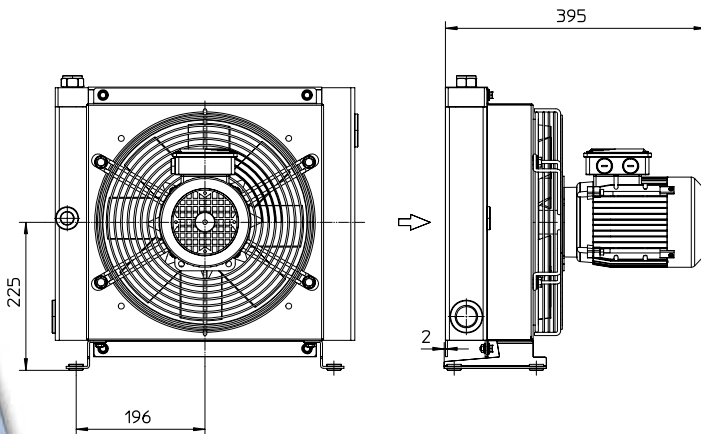

P/N 2W3004###

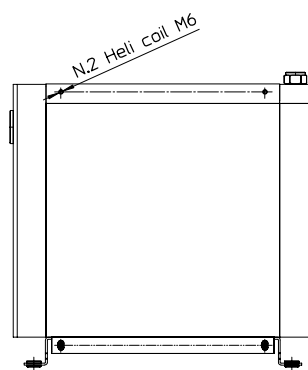
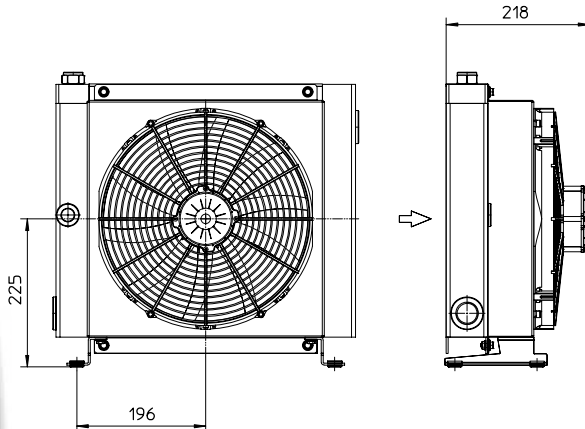

P/N 2W3012###
P/N 2W3024###

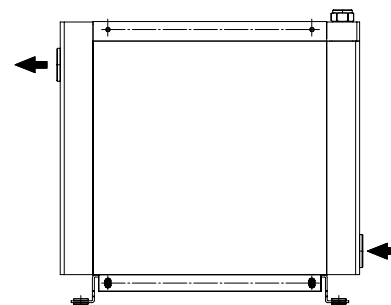
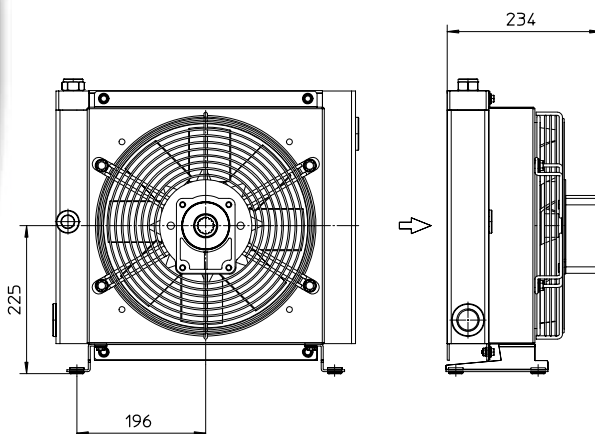

P/N 2W3056###

Le dimensioni di ingombro e le caratteristiche tecniche non sono impegnative
Over-all dimensions and technical characteristic are not binding

MG2030KBV

Dati tecnici Technical Data



P/N	V	Hz	kW	A	rpm	ø Fan	dB(A)	(m³/h)	IP	lt	Kg
2W3001###	230 AC	50	0,189	0,85	2520	300	78	2220	44	1,6	15
2W3003###	230-400 AC	50/60	0,195	0,43	2600	300	76	2500	44		15
2W3004###	230-400 B14 AC	50/60	0,370	1,03	1370	300	70	1850	55		20
2W3012###	12 DC	/	0,180	12,2	3000	305	80	1920	68		14
2W3024###	24 DC	/	0,180	6	3000	305	83	2100	68		14
2W3056###	Prepared for Gr.2 hydraulic monitor					300			/		15

Contattare EMMEGI Contact EMMEGI

Diagramma rendimento Performance diagram

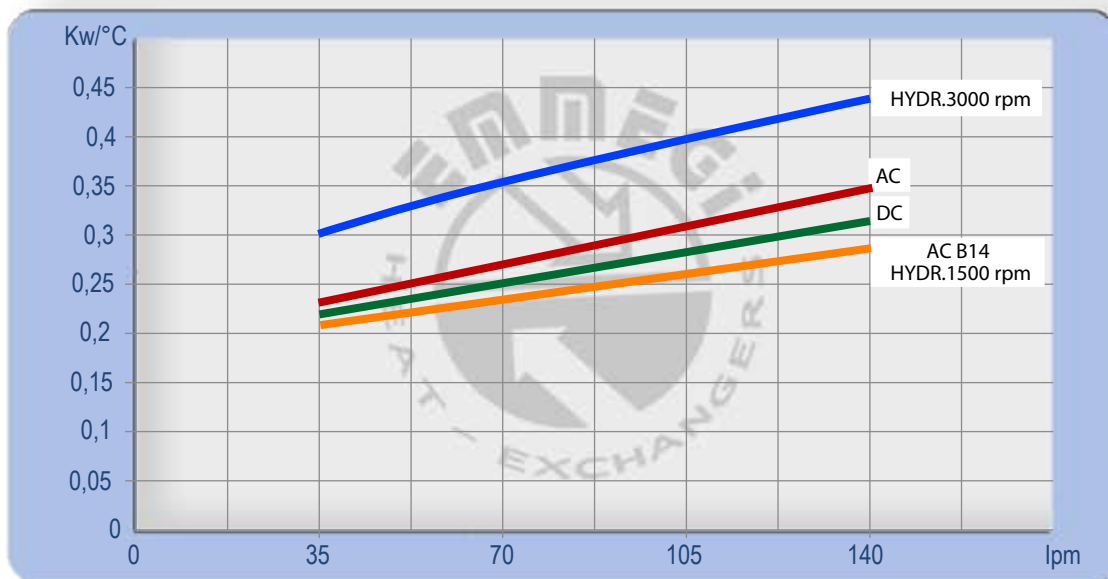

Perdite di carico Pressure drop (ISO VG 32)

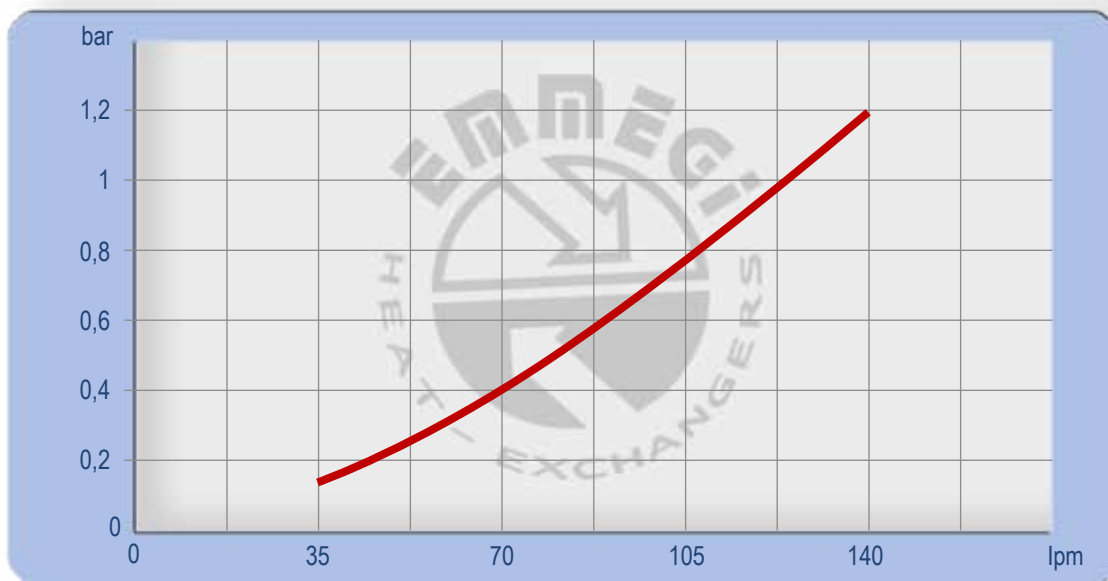

Fattore di correzione - F -(perdite di carico) Correction factor - F - (Pressure drop)

cst	10	15	20	30	40	50	60	80	100	200	300
F	0,5	0,65	0,77	1	1,2	1,4	1,6	1,9	2,1	3,3	4,3

Dimensioni Dimensions

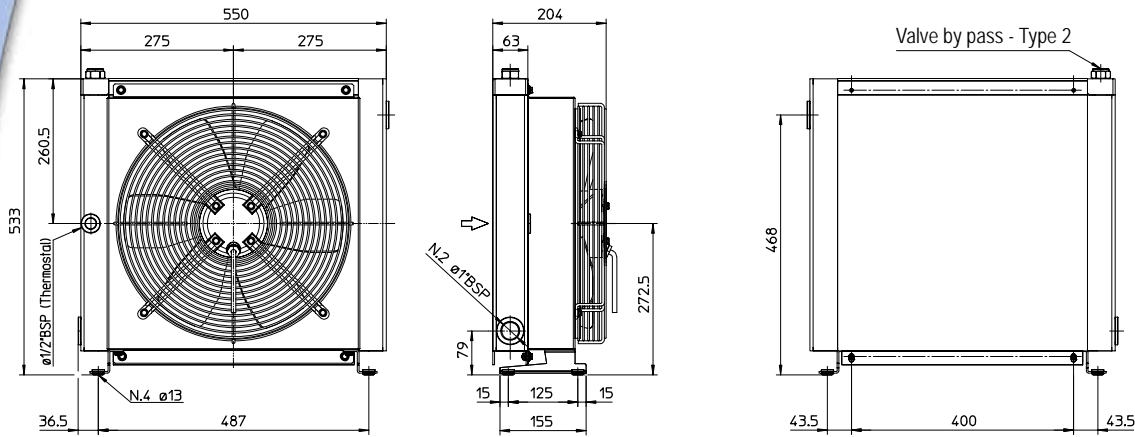

P/N 2W4001###
P/N 2W4003###

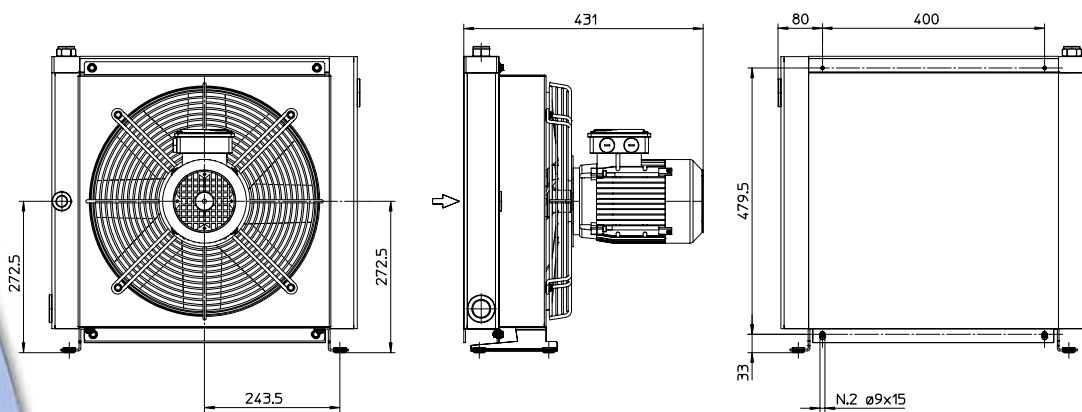

P/N 2W4004###

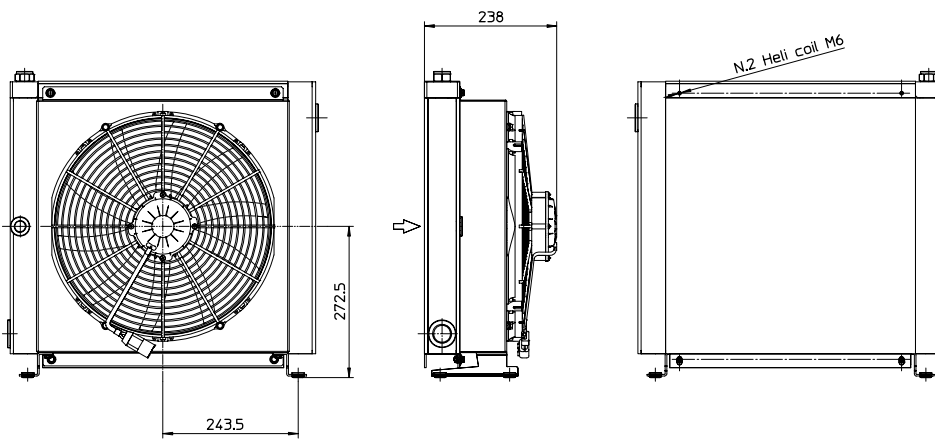

P/N 2W4012###
P/N 2W4024###

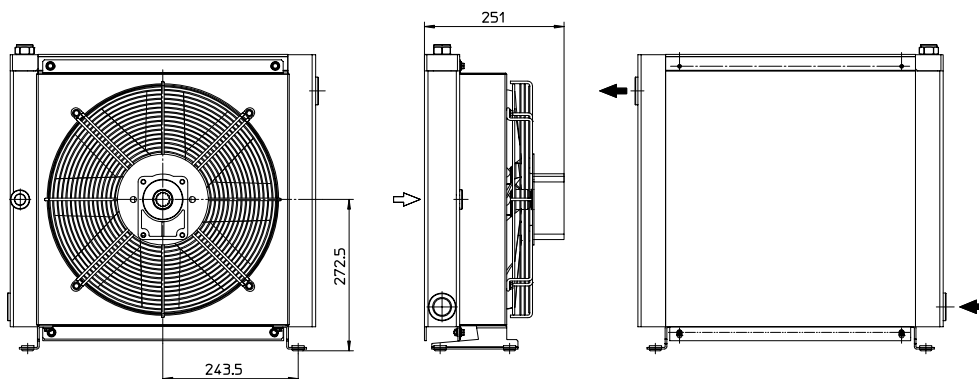

P/N 2W4056###

Le dimensioni di ingombro e le caratteristiche tecniche non sono impegnative
Over-all dimensions and technical characteristic are not binding

MG2040KBV

Dati tecnici Technical Data



P/N	V	Hz	kW	A	rpm	ø Fan	dB(A)	(m³/h)	IP	lt	Kg
2W4001###	230 AC	50	0,32	1,25	1260	400	71	3200	54	2,7	21
2W4003###	230-400 AC	50/60	0,20	0,5	1400	400	71	3200	54		21
2W4004###	230-400 B14 AC	50/60	0,55	1,52	1400	400	77	3740	55		25
2W4012###	12 DC	/	0,21	13,8	2500	385	76	3000	68		20
2W4024###	24 DC	/	0,21	8,2	2500	385	79	3370	68		20
2W4056###	Prepared for Gr.2 hydraulic monitor					400			/		19

Contattare EMMEGI Contact EMMEGI

Diagramma rendimento Performance diagram

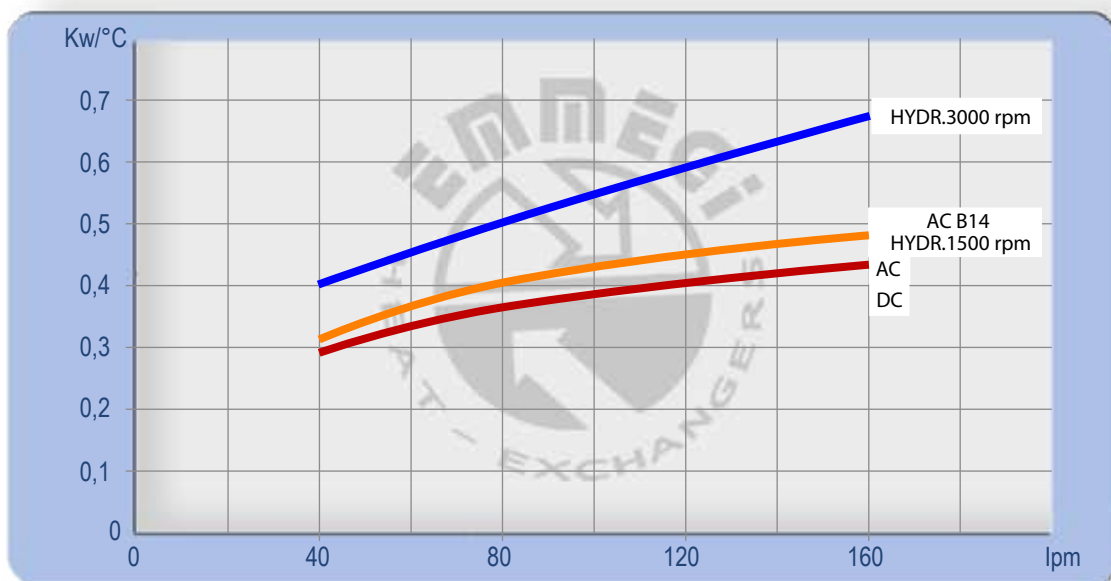

Perdite di carico Pressure drop (ISO VG 32)

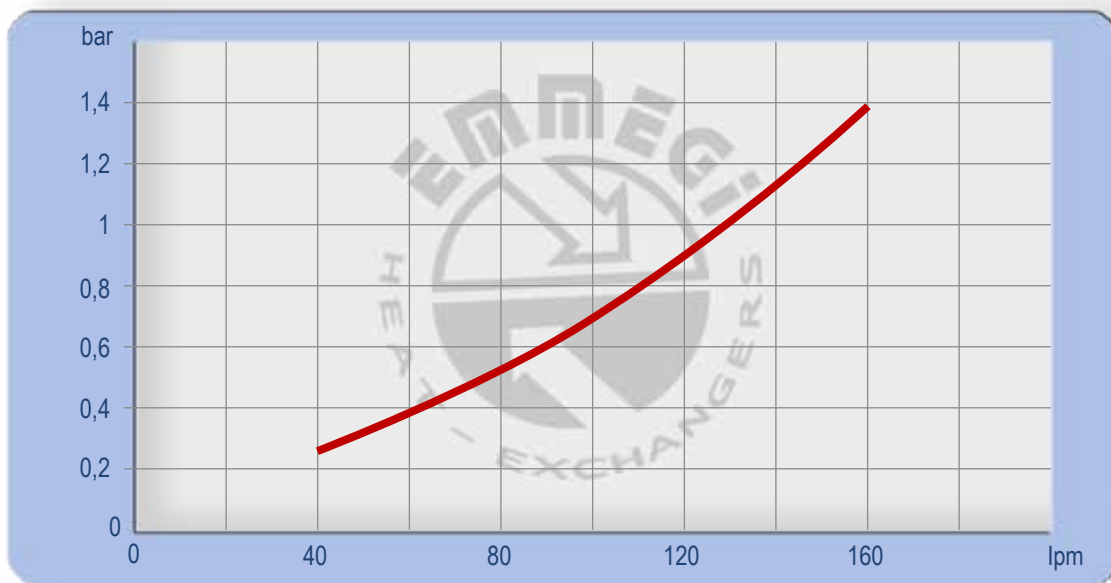

Fattore di correzione - F -(perdite di carico) Correction factor - F - (Pressure drop)

cst	10	15	20	30	40	50	60	80	100	200	300
F	0,5	0,65	0,77	1	1,2	1,4	1,6	1,9	2,1	3,3	4,3

Dimensioni Dimensions

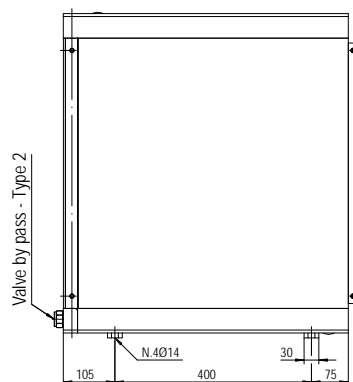
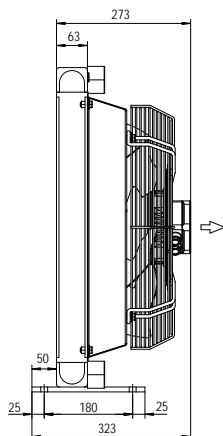
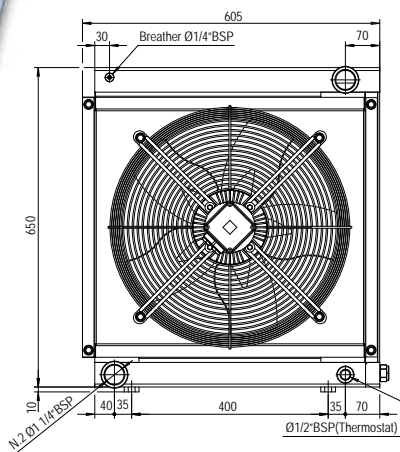

P/N 2W5003###

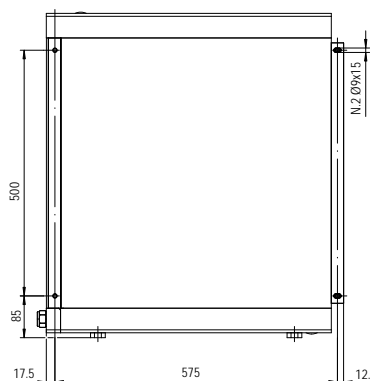
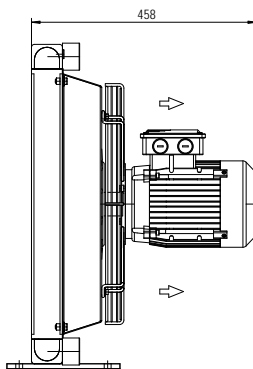
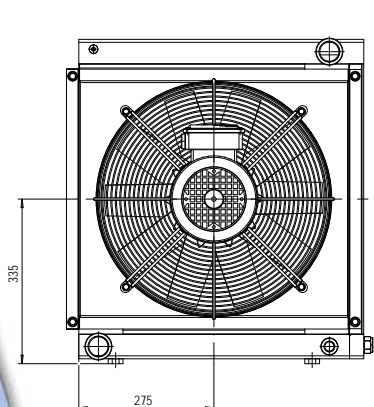

P/N 2W5004###

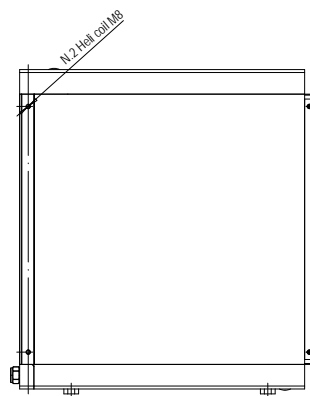
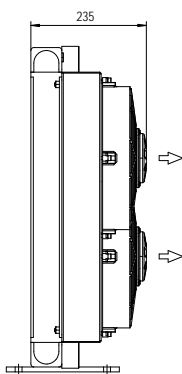
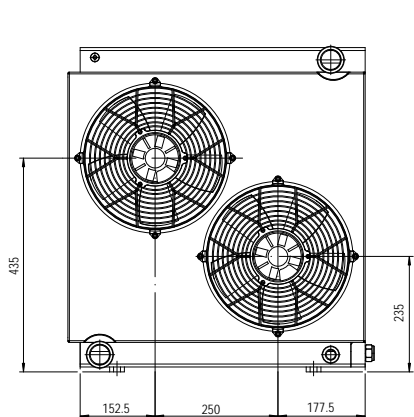

P/N 2W5012###
P/N 2W5024###

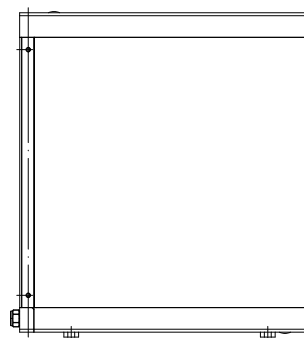
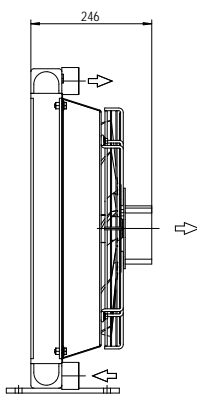
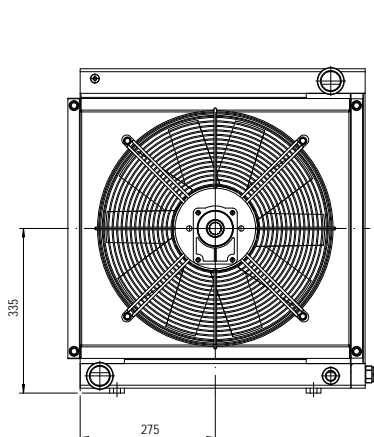

P/N 2W5056###

Le dimensioni di ingombro e le caratteristiche tecniche non sono impegnative
Over-all dimensions and technical characteristic are not binding

MG2050KBV

Dati tecnici Technical Data



P/N	V	Hz	kW	A	rpm	ø Fan	dB(A)	(m³/h)	IP	lt	Kg
2W5003 ###	230-400 AC	50/60	0,43	0,9	1340	450	76	5000	54	5	27
2W5004 ###	230-400 B14 AC	50/60	0,75	1,88	1450	450	79	5200	55		30
2W5012 ###	12 DC	/	0,15	9,5	3100	280	76	2000	68		24
2W5024 ###	24 DC	/	0,15	5,6	3100	280	79	2000	68		24
2W5056 ###	Prepared for Gr.2 hydraulic monitor					450			/		23

Contattare EMMEGI Contact EMMEGI

Diagramma rendimento Performance diagram

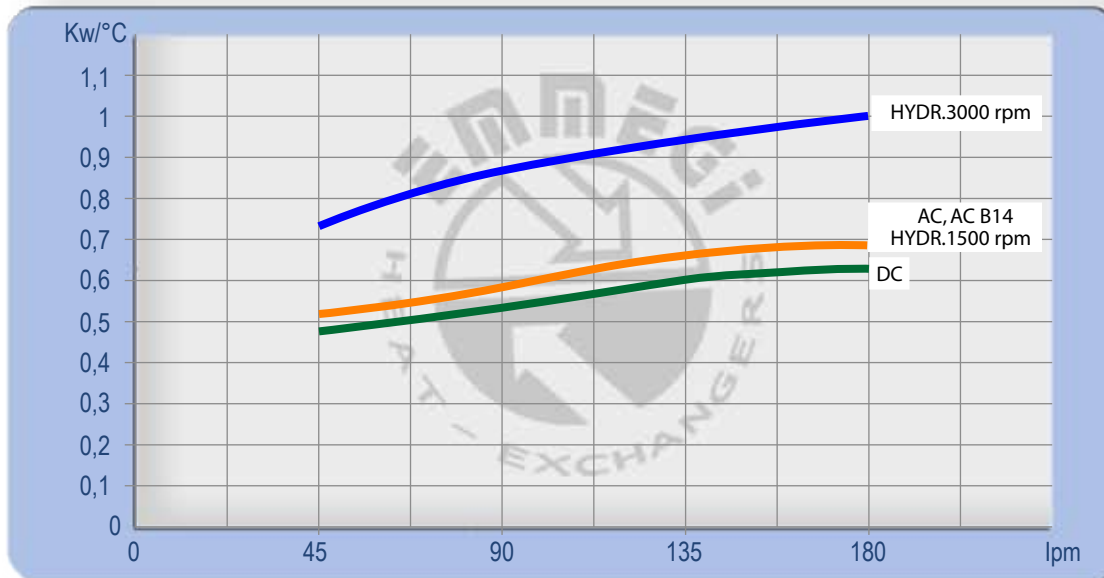

Perdite di carico Pressure drop (ISO VG 32)

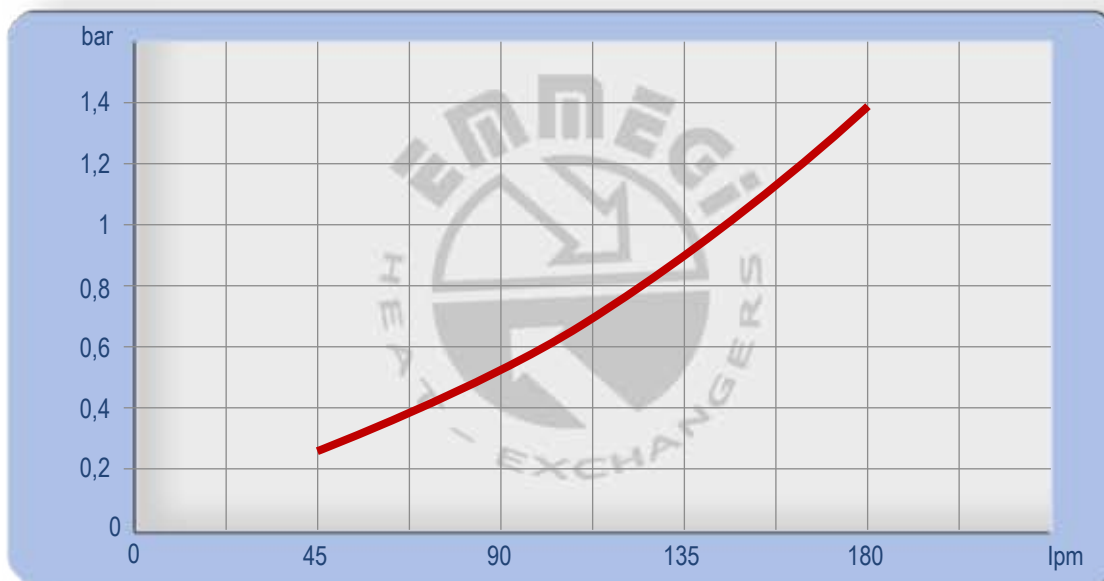

Fattore di correzione - F -(perdite di carico) Correction factor - F - (Pressure drop)

cst	10	15	20	30	40	50	60	80	100	200	300
F	0,5	0,65	0,77	1	1,2	1,4	1,6	1,9	2,1	3,3	4,3

MG2050KBV

USA

EMMEGI HEAT EXCHANGERS Inc.

(Main Office and Manufacturing)

3606 E. Southern Ave. Suite 2

Phoenix, AZ 85040 USA

Ph. +1 602 438 7101

Fax + 1 602 438 7127

<http://www.emmegiinc.com>

sales@emmegiinc.com

CHINA

EMMEGI HEAT EXCHANGERS

(Beijing) Co.,Ltd.

Unit 706,7/ F. Building A, China

Foreign Language Mansion,

89 West, 3 rd Ring (N) Road,

Haidian District,Beijing,

PR.China,Post code: 100089

Ph. + 86 10 88820971- Fax + 86 10 88820972

<http://www.emmegi-heat-exchangers.com>

emmegi@vip.sina.com

SWEDEN/FINLAND

EMMEGI HEAT EXCHANGERS

NORDIC AB.

Box 1136

262 22 ANGELHOLM

Visitors: Nybrovagen 4

Ph. + 46 (0) 431- 415096

Fax + 46 (0) 431- 415099

<http://www.emmegi-heat-exchangers.com>

info.nordic@emmegi-heat-exchangers.com

UK

EMMEGI UK

(Sales Office)

Evergreen, The Reddings

Cheltenham GL51 6RL

Ph. + 44 1242700151

Fax + 44 8707577659

<http://www.emmegi.co.uk>

sales@emmegi.co.uk

BRAZIL

EMMEGI BRAZIL

(Sales Office)

Rua Arno Luckow 61

Bairro Gloria - Joinville - SC - Brazil

89.217 - 211

Ph. +55-47-3422-1903

Mobile +55-47-9971-1763

<http://www.emmegi-heat-exchangers.com>

paulob@emmegi-heat-exchangers.com

ASIA / PACIFIC

EMMEGI HEAT EXCHANGERS Ltd

Unit 17.9/ F.Corporation Park,

11 On Lai Street, Siu Lek Yuen,

Shatin, Hong Kong

Ph. + 852-26473488- Fax + 852-26032119

<http://www.emmegi-heat-exchangers.com>

emmegi@biznetvigator.com

GERMANY

EMMEGI GmbH

-Wärmetauscher-

Am Hagelkreutz 13 - D 41469 Neuss

Ph. +49 213778720 - Fax +49 2137787229

vertrieb@emmegi-gmbh.de

<http://www.emmegi-gmbh.de>

SLOVAKIA

EMMEGI HEAT EXCHANGERS s.r.o.

Ul. M.Razusa 1

95514 Topolcany

Ph. + 421 387629212 - Fax + 421

387629222

<http://www.emmegi-heat-exchangers.com>

sro@emmegi-heat-exchangers.com

ITALIA

EMMEGI S.p.A.

Via Newton,52 - Zona Industriale

20062 Cassano d'Adda (MI) - Italy

Tel. +39 0363 360236 - Fax + 39 0363 360230

<http://www.emmegi-heat-exchangers.com>

info@emmegi-heat-exchangers.com

